

Notes:

1. Place the P8 | P9 connector footprint on the PCBA "Bottom", then install the part from the "Top".
2. Place all test points on the PCB "Bottom" for ICT.

BBB P9 Interface

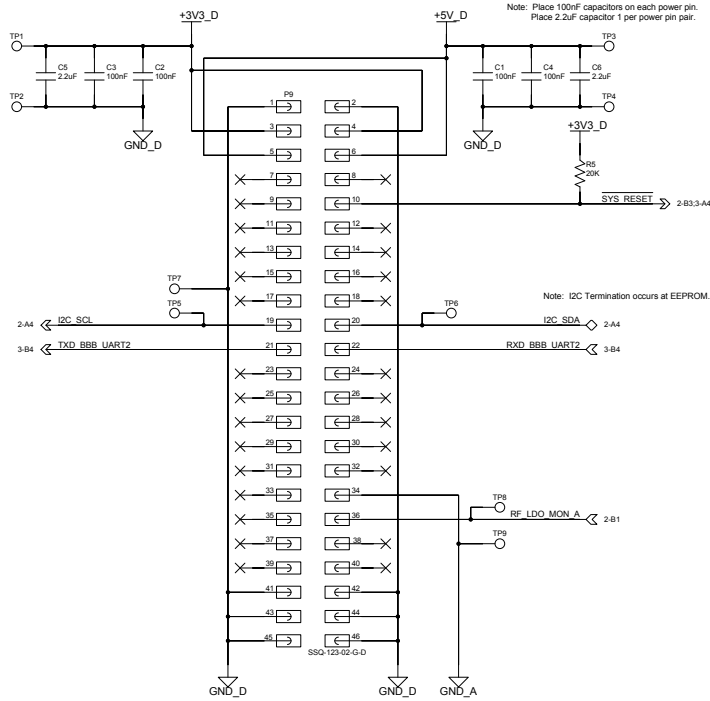

BBB P8 Interface

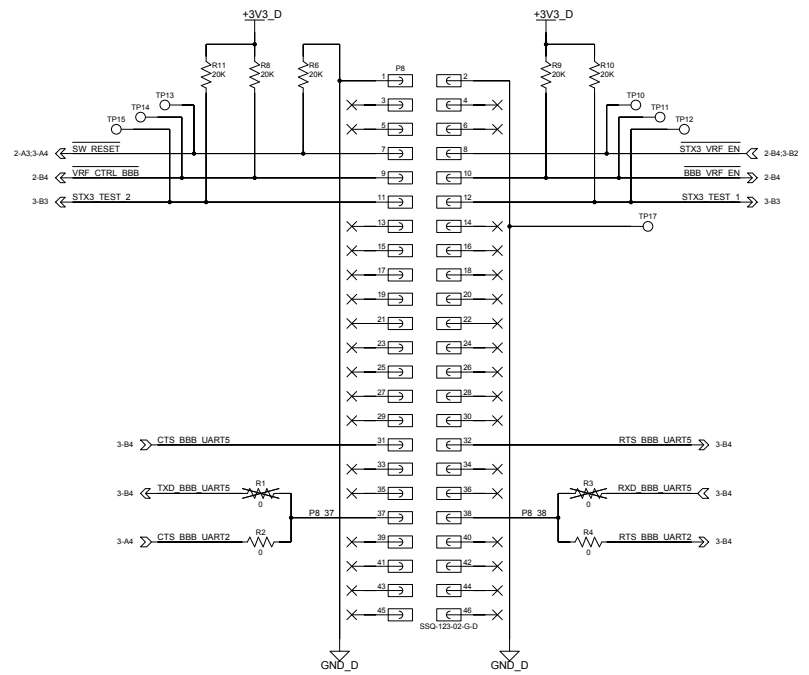

STX3 RF Antenna

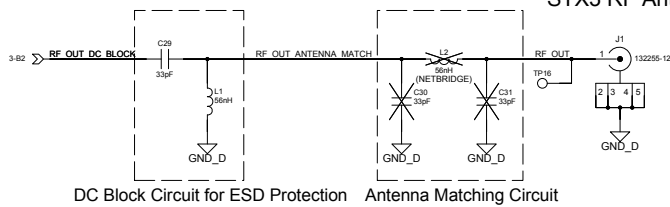

TITLE			
LinkStar-STX3 BBB-Cape			
SIZE	DWG NO	REV	
B	00000001-01	Schematic Connectors	B
DRAWN BY		SHEET	of
SATech		1	3
22/05/2016:14:11			